

# HP FUEL PUMP

## LITRESTROKE™ / QUART STROKE

### INSTRUCTION MANUAL



#### Introduction

Thank you for purchasing a Macnaught model HP LITRESTROKE / QUART STROKE Manual Fuel Pump.

Please read and retain this instruction sheet to assist you in the operation and maintenance of this product. Take particular note of all warnings and safety messages.

#### DESCRIPTION

Your Macnaught HP Fuel Pump is a piston type pump designed to dispense petrol, kerosene, and light petroleum based oils up to SAE30 viscosity.

Features of your pump include a long life, anti-static rubber hose, leaded / unleaded petrol nozzle, covered nozzle holder, lockable handle and an easy, 1 litre per stroke 'rowing' pump action.

An optional Model HA Fuel Filter kit is available from your Macnaught dealer. This kit contains the filter assembly and fittings required to connect the filter to your pump. The filter features a 10 micron, fast flow filter element to ensure only clean fuel reaches your valuable machinery.

#### IMPORTANT

**This pump is designed for use with petroleum fuels only, such as unleaded / leaded petrol, diesel, kerosene and light mineral oils up to SAE30. Do not use this pump for dispensing fluids other than those for which it was designed. To do so may damage pump seals and / or other components and will void the warranty.**

Mild Steel components which are liable to rust / corrode are used in the construction of this pump. Macnaught does not recommend this pump for aircraft refuelling. Contact local aviation authorities for aircraft refuelling procedures.

#### ASSEMBLY

The carton contains the Pump Assembly, Two piece suction tube, Hose Assembly and a Plastic Bag containing a Hose Clamp and this Instruction Sheet.

- 1) Apply fuel resistant thread sealant to the male threads on the 3 piece suction tube.
- 2) Screw suction tubes firmly together.
- 3) Screw the Suction Tube assembly into the pump. Use a pipe wrench to ensure a good fit.



- 4) Screw the Lock Nut up to the top of the thread and screw the pump into the drum / tank bung 4 or 5 turns. Tighten the lock nut firmly onto the bung.

- 5) Slide the Hose Clamp onto the Hose Assembly. Fit the Hose Assembly to the Pump and tighten the hose clamp.



#### WARNING

**Handling flammable liquids is hazardous. There is the potential for an explosion and / or fire. Your personal safety, and the safety of others is at risk. It is the user's responsibility to know and follow all safety precautions when handling flammable liquid and to ensure all equipment operators have adequate instructions concerning safe procedures.**

**Follow all recommended safety precautions, including those listed on page 2 of this instruction sheet, when handling flammable liquids such as petrol.**

## OPERATION

1) Place the nozzle into the fuel tank or receiving vessel. You will need to pull back the outer sleeve of the nozzle to fit the small, unleaded petrol, filler orifice. Occasionally, apply some light oil to the inner tube, to allow easy movement of the outer sliding tube.

2) If there is a kink in the hose, move one of the hose springs over the kink.

3) The pump primes on the 'push' (towards pump outlet) stroke and delivers on the 'pull' stroke. Take care to avoid fuel splashing or spillage.

4) When finished pumping, return the nozzle to the nozzle holder. Position the lug on the sliding outer nozzle tube so that it rests to the right of the vertical in the holder, that is, the hose must be twisted anti-clockwise to remove the nozzle. This will help prevent the hose from accidentally falling from the holder.

## IMPORTANT

**Under certain conditions this pump may syphon. Always replace the nozzle in the nozzle holder when finished pumping. Slide the outer nozzle tube forward and position the lug so that it rests to the right of vertical in the holder.**

5) Your HP fuel pump is fitted with a handle locking device. Position the handle vertically and place the locking bar over the locking lug welded to the pump. Fit a padlock with a 6mm diameter shackle (not supplied).

## OPTIONAL HA FUEL FILTER

The HA Fuel Filter is particularly recommended for diesel fuel users. The Filter Kit is complete with all the fittings to enable fast, simple installation. The Filter features a 10 micron filter element, a see-through bowl and drain-tap.

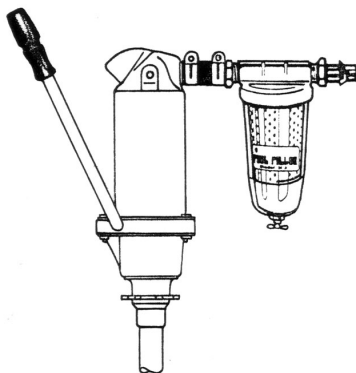

## WARNING

To avoid static electricity build up, DO NOT use teflon tape or equivalent when connecting either a filter or meter to this pump



## WARNING

**Pumping petrol and other flammable liquids is hazardous.**

An explosion or fire can occur if there is a flammable vapour / air mixture and a source of ignition.

Follow all precautions listed below to reduce the risk of explosion or fire or injury.

\* Pumping should only occur in well ventilated areas. Never fill containers in confined areas e.g. inside a vehicle. Do not operate the pump in areas where vapours can accumulate.

\* Do not smoke while refuelling. Do not fill vehicle or equipment fuel tanks when the engine is running or hot. Keep fuel away from open flame or spark.

Precautions are necessary to minimise the build-up of a static charge, which could cause a spark.

\* Your Macnaught HP Fuel Pump is supplied with a hose designed to reduce the opportunity for static charge to accumulate. Always use a Macnaught branded anti-static hose when pumping petrol and other flammable liquids.

\* Fuel storage tanks and drums should be metal and grounded to earth. Ensure the floor or ground where the fuel is stored or dispensed is and remains conductive. Keep storage and dispensing areas clean because fuels, oils, resins, waxes or other materials may insulate storage tanks / drums, and / or pump operator, and / or receiving vessel / equipment from earth.

\* Wear anti-static or conductive footwear and avoid wearing silk and / or synthetic clothing, unless treated with anti-static solution.

\* Avoid prolonged skin contact with petroleum fuels. Use of protective goggles, gloves and aprons is recommended in case of accidental splashing or spillage. Change saturated clothing and wash skin contact areas promptly with soap and water.

## PARTS DIAGRAM

### IMPORTANT

The Earthing Spring (27) must make good, clean contact with both the Cylinder (1) and the Lower Body Assembly (18) to ensure the continuity of an electrically conductive path through the pump.

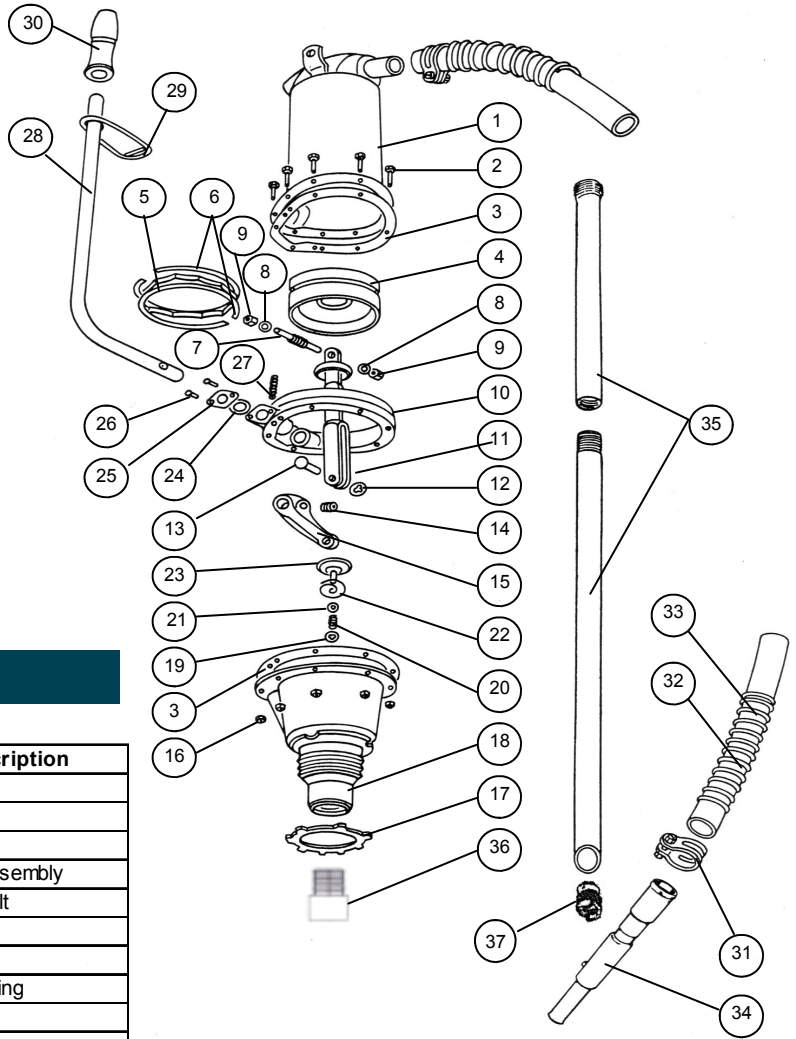

### PARTS LIST

		Order for replacement		
Item	No off	Part / set	Kit ref	Description
		HO-1K ( KIT A )		Service kit
1	1	HM14s		Cylinder assembly
2	8		A	Cylinder bolt
3	2		A	Gasket
4	1		A	Piston
5	1		A	Expander ring
6	2		A	Piston ring
7	1			Cross bar
8	2	HM6s		Shakeproof washer
9	2			Hex nut
10	1	HM50s incl 2 x HM19		Bearing sandwich
11	1			Con rod assembly
12	1		A	Ratchet plate
13	1	HM8s	A	Con rod pin
14	1		A	Clevis screw
15	1		A	Clevis
16	8		A	Cylinder nut
17	1		A	Lock nut
18	1	HP25s incl TH011		Lower body assembly
19	1		A	Ratchet plate
20	1		A	Valve spring
21	1		A	Washer
22	1		A	Retainer
23	1		A	Inlet valve
24	1		A	O'ring (BS114)
25	1		A	Retainer plate
26	2		A	Self tap screw
27	1		A	Earthing spring
28	1			Pump handle
29	1			Locking bar
30	1			Handle
31	2			Hose clamp
32	2	HM70s		Hose spring
33	1			Anti static hose (2.4M)
34	1	HNU		Nozzle
35	1			Suction tube
36	1		ST002As	Adapter
37	1	AG54s		Footvalve



## CAUTION

If carrying out maintenance on this pump, for your own protection, thoroughly drain the pump and hose before disassembly. Clean all components as they are removed from the pump. Follow all precautions when handling flammable liquids. (see page 2)

### Troubleshooting Guide

TROUBLE	CAUSE	REMEDY
Fuel leaks at the retainer plate (25) when pumping.	O'ring seal (24) worn or damaged.	Replace o'ring (24):
		1) Remove the handle knob (30) and the locking bar (29).
		2) Remove the 2 screws (26) and the retainer plate (25).
		3) Remove the old o'ring.
		4) Apply oil to the new o'ring and slide it over the handle (28) and into the groove.
		5) Reassemble.
		<b>Note: Push the plug out of the top of the handle knob (30), hammer the knob onto the handle then replace the plug.</b>
Handle (28) is loose and unit will not pump.	Clevis (15) is broken or the Connecting Rod Pin (13) is dislodged.	Replace the clevis (15) or connecting rod pin(13):
		1) Remove the 8 x nuts (16) and bolts (2).
		2) Separate lower body (18), handle / bearing sandwich assembly and cylinder (1).
		3) Use a hammer and pin punch to remove the connecting rod pin (13).
		4) Remove the clevis screw (14) and clevis.
		5) Withdraw the handle (28) from the bearing sandwich (10) sufficiently to allow fitting of the new clevis (15). Clevis screw (14) must bite into the hole in the handle (28).
		6) Use a socket and hammer to fit the ratchet plate (19) to the connecting rod pin (13).



Macnaught Pty Limited  
ABN 66 000 075 786

41-49 Henderson Street  
Turlella NSW 2205 Sydney Australia  
Postal Address PO Box 90  
Arncliffe NSW 2205 Sydney Australia

T: +61 2 9567 0401  
F: +61 2 9597 7773  
W: [www.macnaught.com.au](http://www.macnaught.com.au)

**Note:**

This product should be disposed of according to all applicable local and national government environment regulations and guidelines.



**For Warranty Terms and Conditions see [macnaught.com.au](http://macnaught.com.au)  
For a list of Australian Service Centres see [macnaught.com.au](http://macnaught.com.au)**